

Briquetting saw 06-V2

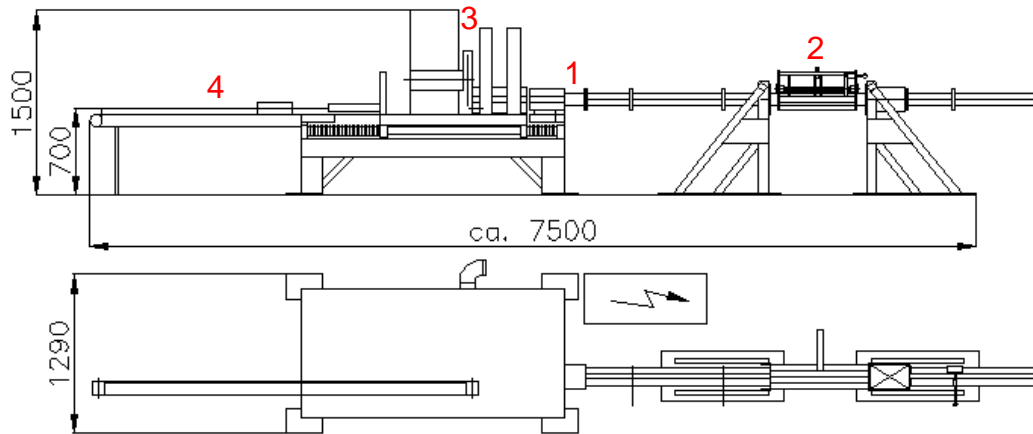

- | | | |
|---|-------------------------|--|
| 1 | Supply | - Connection for the cooling line |
| 2 | Switch with compensator | - Safety mechanism in case of malfunctioning of the briquette saw
Compensator needed when cooling line is longer then 45m |
| 3 | Saw blade | - Cut-off the logs |
| 4 | Outfeed conveyor | - Convey the logs out off he saw |

Technical specifications of the briquetting saw

Capacity	- 1'200	kg/h	
Weight of the briquetting saw	1'000	kg	
Dimension incl. switch	7,50	m	length
	1,30	m	width
	1,50	m	height
Electrical supply data	6	kW	saw engine (3x400/230V, 50Hz)
Compressed air	60	Nm ³ /h	at 10 bar
Others			exhaust ventilation
Environmental temperature	10	°C	not below

Scope of delivery

- 1 Switch with compensator (Compensator when cooling line is longer then 45m)
- 1 Saw blade
- 1 Out feed conveyor
- 1 Electric control panel